

The CME6005 is a BiCMOS integrated straight through receiver with build in very high sensitivity for the time signal transmitted from WWVB, DCF77, JJY, MSF and HBG. The receiver is prepared for single-and dual band (by using additional capacitor matching pin) reception.

The CME6005 can serve as a direct substitution to some radio controlled receiver IC's that was on the market, but some particular attention need to be given to ensure the best of performance.

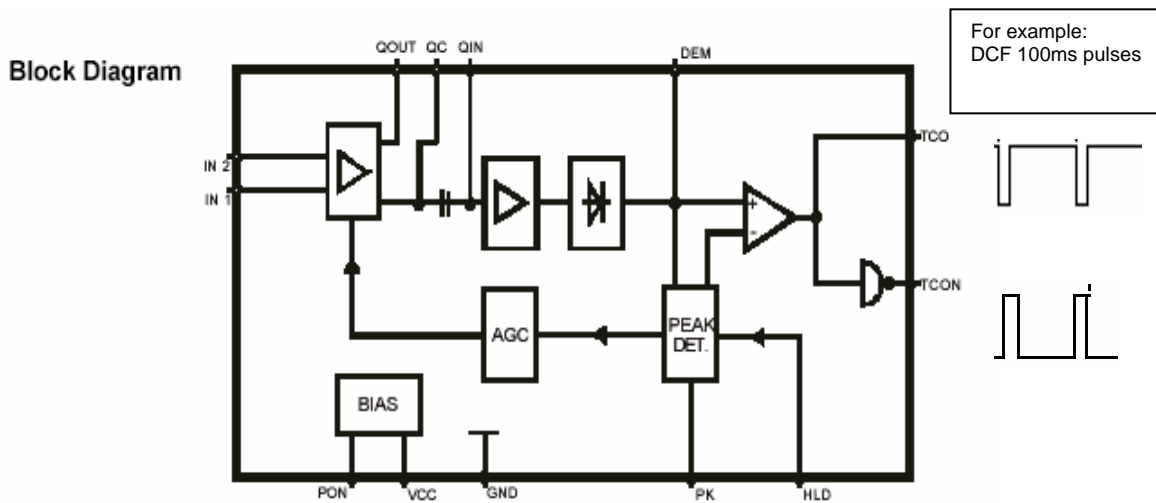

1. Output Stages

One main difference between the CME6005 and some other receiver IC's is the connections at the analog output stages, sometimes called TCO or OUT pins.

The serial signal of the time-code transmitter given out from the TCO or TCON can be directly decoded by a micro controller. TCO gives out a direct demodulated wave form from the IC and the TCON gives out an inverted waveform from the IC.

If TCO is connected, TCON must be open, and vice versa. However, **no pull up or pull down resistors** are required at these output pins. Addition of any components at the output pins may overload the output stage and cause degradation in sensitivity.

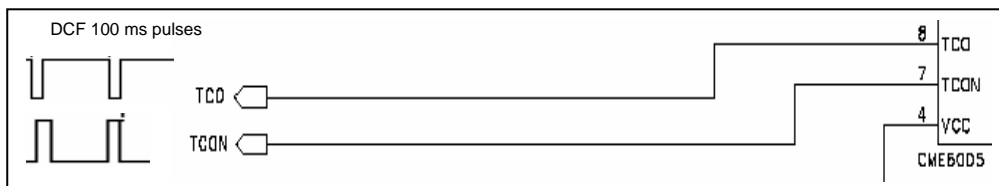

2. AGC Hold (HLD)

AGC hold mode: HLD = high (VHLD = VCC) means no hold, HLD = low (VHLD = 0) applies hold action to the internal automatic gain control (AGC) inside the CME6005. This can be used to prevent the AGC from peak voltages, created by e.g. a stepper motor.

One important note on this pin is that the AGC HLD pin **MUST NOT be left open**. It must be connected to the defined HIGH (VCC or VDD) or defined LO (GND).

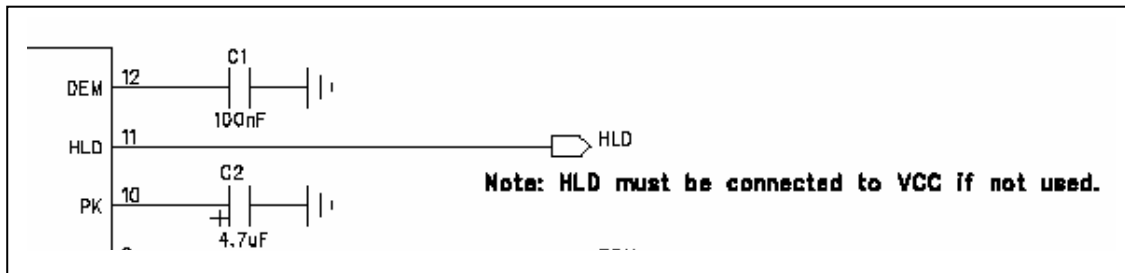

3. Use of QC pin

The QC pin is only used when two high selectivity crystals, with a total shunt capacitance of > 1.6 pF (including internal capacitor + parasitic capacitance on PCB) are used for dual frequency applications on the CME6005.

If only one crystal is used (i.e. for **single band** applications), this **QC pin should be left open and not bonded to the PCB**.

For **dual frequency applications**, if both crystals connected in parallel gave a total shunt capacitance of, for example 2.9 pF. Then a capacitor of $2.9 - 1.6 \text{ pF} = 1.3 \text{ pF}$ should be connected between the QC and the QIN pin. This compensation technique works most favorably for crystals with a reasonable steep selectivity curve.

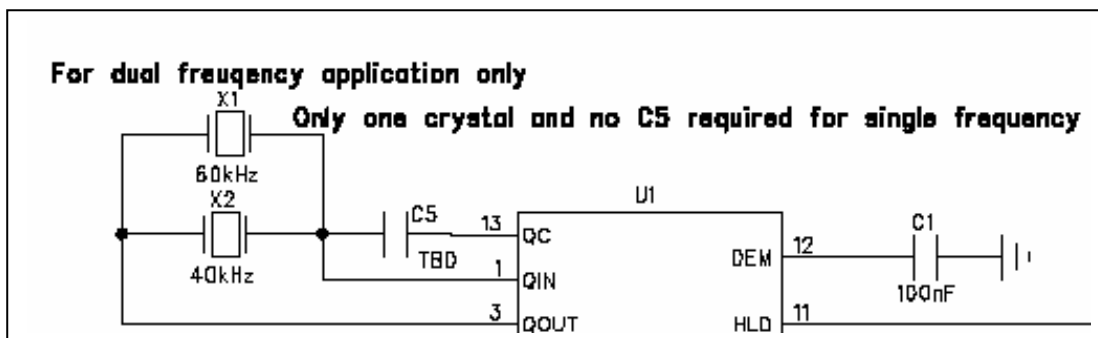

4. Power On pin (PON)

The **CME6005 is active LO**, which means that the receiver IC will be powered on if a LO signal (or GND) is applied to the PON pin. The receiver IC will be turned off if a HI signal (or VCC) is applied to the PON pin. Do not in any case leave this pin open.

5. Antenna input characteristics

The CME6005 requires a **resonant resistance at the antenna inputs IN1 and IN2 of 40 kΩ to 100 kΩ**. This can be achieved by a variation of the L/C-relation in the antenna circuit. In order to achieve this resonant resistance, we recommend to use antenna capacitors of a value between 2.2nF and 6.8nF, and thus from simple LC resonance circuitry calculation, will not require an antenna inductance of above 4 mH (which is required for some other receiver ICs on the market).

6. DEM and PK capacitors

The DEM capacitor influences the stability of the demodulator output. The PK capacitor value influences the AGC regulation time. Note that the suggested values may be different for different PCB layouts and some fine tuning of the DEM capacitor may be necessary to achieve the optimum sensitivity. However, it is not recommended to change the PK value.

	Cdem	Cpk
DCF	47nF	4.7μF
WWVB	100nF	4.7μF
JJY60	100nF	4.7μF
MSF	100nF	4.7μF
JJY40	100nF	4.7μF

6. Ground Connections of IC

There are two ground connections required to the CME6005. One is the **ground pin** on the IC and the other is the **substrate to the IC**. To ensure optimal performance, it is important that these two grounds should not be connected together through one signal ground via hole. **Two separate via holes to ground plane** will give a better performance in terms of sensitivity.

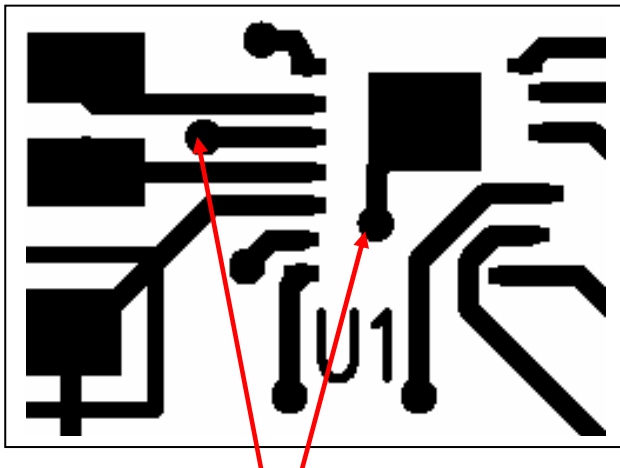

Ground Connection Vias

Disclaimer of Warranty

Information furnished is believed to be accurate and reliable. However C-MAX assumes no responsibility, neither for the consequences of use of such information nor for any infringement of patents or other rights of third parties, which may result from its use. No license is granted by implication or otherwise under any patent or patent rights of C-Max. Specifications mentioned in this publication are subject to change without notice. This publication supersedes and replaces all information previously supplied. C-MAX products are not authorized for use as critical components in life support devices without express written approval of C-MAX.

Note

It is not given warranty that the declared circuits, devices, facilities, components, assembly groups or treatments included herein are free from legal claims of third parties.

The declared data are serving only to description of product. They are not guaranteed properties as defined by law. The examples are given without obligation and cannot given rise to any liability.

Reprinting this data sheet - or parts of it - is only allowed with a license of the publisher.

C-MAX reserves the right to make changes on this specification without notice at any time.

C-MAX Time Solutions GmbH

Carl-Zeiss-Str. 13
74078 Heilbronn

Tel.: +49-7066-900400

Fax: +49-7066-9004029

e-mail: contact@c-max-time.com

Data sheets can also be retrieved from our Internet homepage: www.c-max-time.com